

disabled person's call system

The Wandsworth Disabled Person's Call System, for use in toilets and bathrooms fully complies with the guidelines outlined in BS8300:2001 Section: 12.4.10.

The system comprises of the following components and is also available as a complete 'boxed' kit for ease of specification and ordering. (QD350 – see bottom of page).

Within toilet cubicle



QD351 Ceiling pull

White surface mounting ceiling pull.
Integral reassurance lamp 2.5watt with amber lens.
3 m red pull cord, complete with 2x50mm red 'bangles' as specified in BS8300:2001.
Unit fits BS31 box with 50.8mm centres.



QD324 Reset unit

Used in conjunction with the QD351 ceiling pull.
Front cover plate 146mm x 86mm containing:
Reset push with integral reassurance lamp 1.1watt with amber lens.
Front plate engraved 'RESET'.
PCB with components wired to terminal block.
Plate size: 86mm x 146mm
Box flush: 1703. Box surface: 1133.

Outside toilet cubicle



QD332 Overdoor lamp/tone generator

Front cover plate 146mm x 86mm containing:
One 2.8watt MES lamp. (Lenses, QD337, are to be ordered separately: see across for details).
Mini bleep-tone generator.
Components wired to terminal block.
Plate size: 86mm x 146mm
Box flush: 8302. Box surface: 8387.

QD337 Overdoor lamp lenses

Lamp lenses, 36mm square, are available in amber (A), red (R), green (G), blue (B) or clear (CL). Please specify colours and quantities of each required.

QD153 Power unit

Input 230V 50Hz, an earth connection is required. Rated output 1A 24Vdc.
Output fuse 1A quick blow 20 x 5mm (spare part No. XR603).
Size: 200mm long x 100mm wide x 100mm high. Weight: 1.5kg.

Complete system (flush mounting)

QD350

Comprises: 1 – QD351; 1 – QD324 + Flush Box; 1 – QD332 + Flush Box; 1 – QD153

Other options

The Wandsworth Disabled Person's Call System components are part of the QD range of nurse call equipment from Wandsworth. Other components within this range can be used to supplement the Disabled Person's Call System as follows:-



QD321 Call unit

Can be used within the toilet or bathroom as an additional call point to the QD351 ceiling pull.
Plate size: 86mm x 86mm
Box flush: 1702
Box Surface:1132



QD331 Single overdoor lamp unit

Can be used outside of the toilet or bathroom facility to indicate remotely that a call has been initiated within the toilet or bathroom.
Plate size: 86mm x 86mm
Box flush: 1702
Box Surface:1132

Remote indicator panels for multiple disabled person's call systems



QD340 Three Section Indicator Panel

3 x 1.1watt indicator lamps with amber lenses 22mm x 16mm.
Mini bleep-tone generator and rocker switch for muting bleep-tone.
Components wired to terminal block.
Plate size: 172mm square.
Box flush: 8306
Box surface: 8374



QD341 Six Section Indicator Panel

Generally as QD340' but containing 6 indicator lights.
Plate size: 172mm square.
Box flush: 8306
Box surface: 8374

Wiring diagram

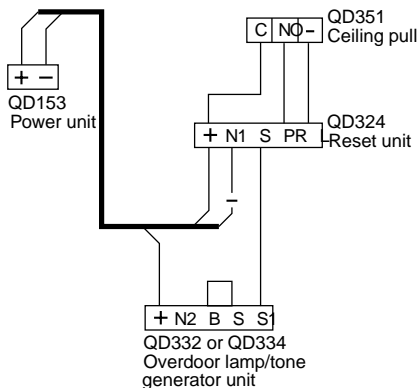

Wiring diagram of installation for disabled person's call system

The panel would normally be located in a centrally staffed area (eg. reception) of the building and all toilet/bathroom calls would be routed back for indication of alarm calls.

Note: For larger systems or long distance wiring please refer to the Wandsworth Technical Services department for advice on power supplies required.